

## OFFICIAL COORDINATION REQUEST FOR NON-ROUTINE OPERATIONS AND MAINTENANCE

**COORDINATION TITLE-** 18BON03 WA Shore lamprey passage structure (LPS) plunge box and Adult Fish Facility (AFF) lamprey trap installation (Updated)

**COORDINATION DATE-** 09 April 2018

**PROJECT-** Bonneville Dam

**RESPONSE DATE-** 12 April 2018

### Description of the problem

Request to conduct work within 50 feet of the Washington shore fish ladder (FPP section 2.1.5) to install a plunge box and adult lamprey trap in the AFF fish ladder (figure 1).

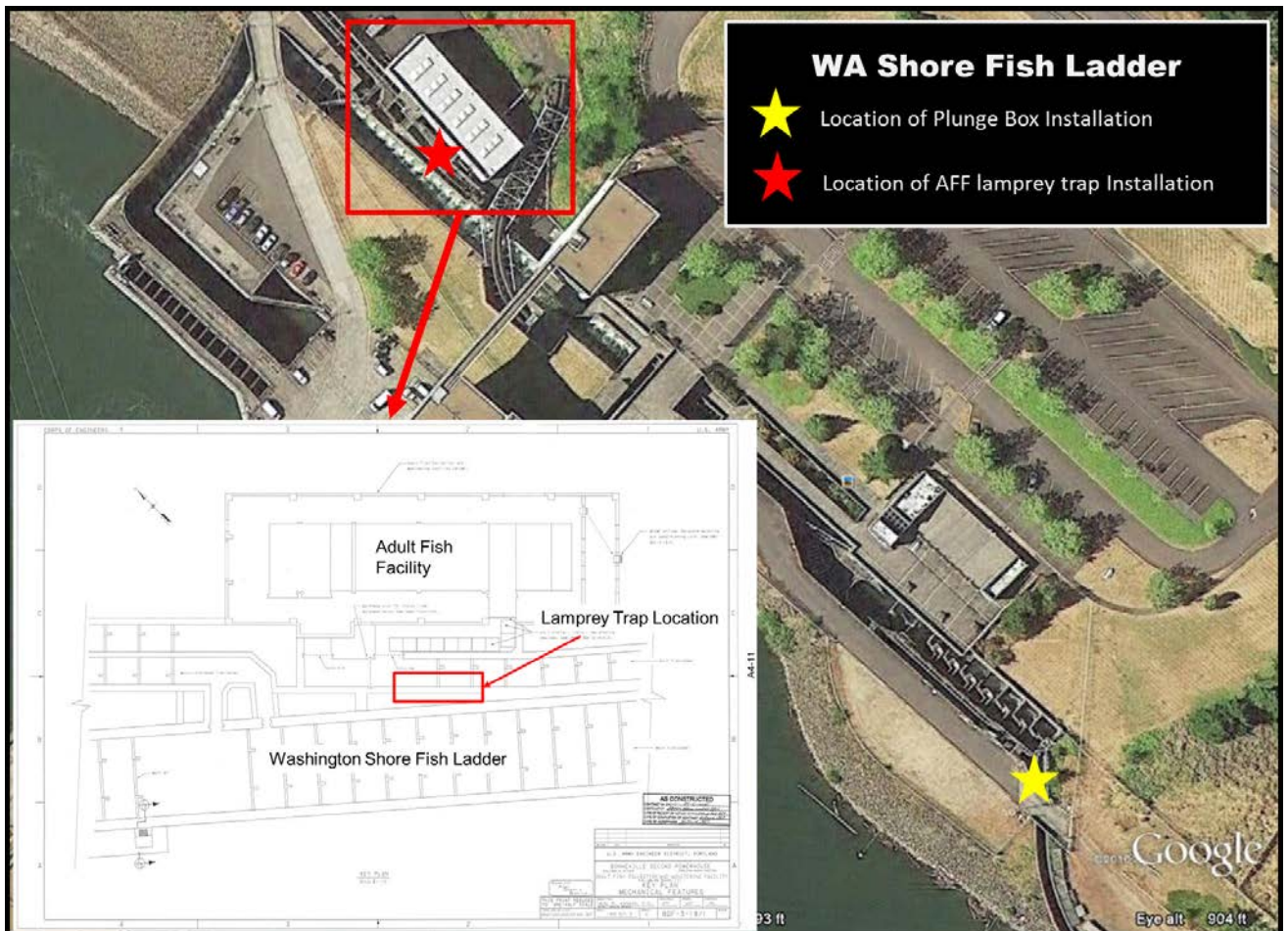

**Figure 1.** Location of the LPS plunge box installation and the adult lamprey trap in the adult fish facility ladder.

### Adult Fish Facility Adult Lamprey Trap Installation

The lamprey trap was reviewed and approved by the Fish Facility Design Work Group and is being supplied by contractor to the Bonneville Dam at the end of March (figure 2). It is schedule to be installed mid-April 2018. The installation will require work to be conducted in the AFF fish ladder which is within 50 feet of the WA shore fish ladder. The AFF ladder will be dewatered until **April 23rd** and will be coordinated with Bonneville project and other facility users (i.e., Columbia River Inter-Tribal Fish Commission). Installation will **require 2 full days April 18th and 19th**. The installation will be done with hand tools and crane support.

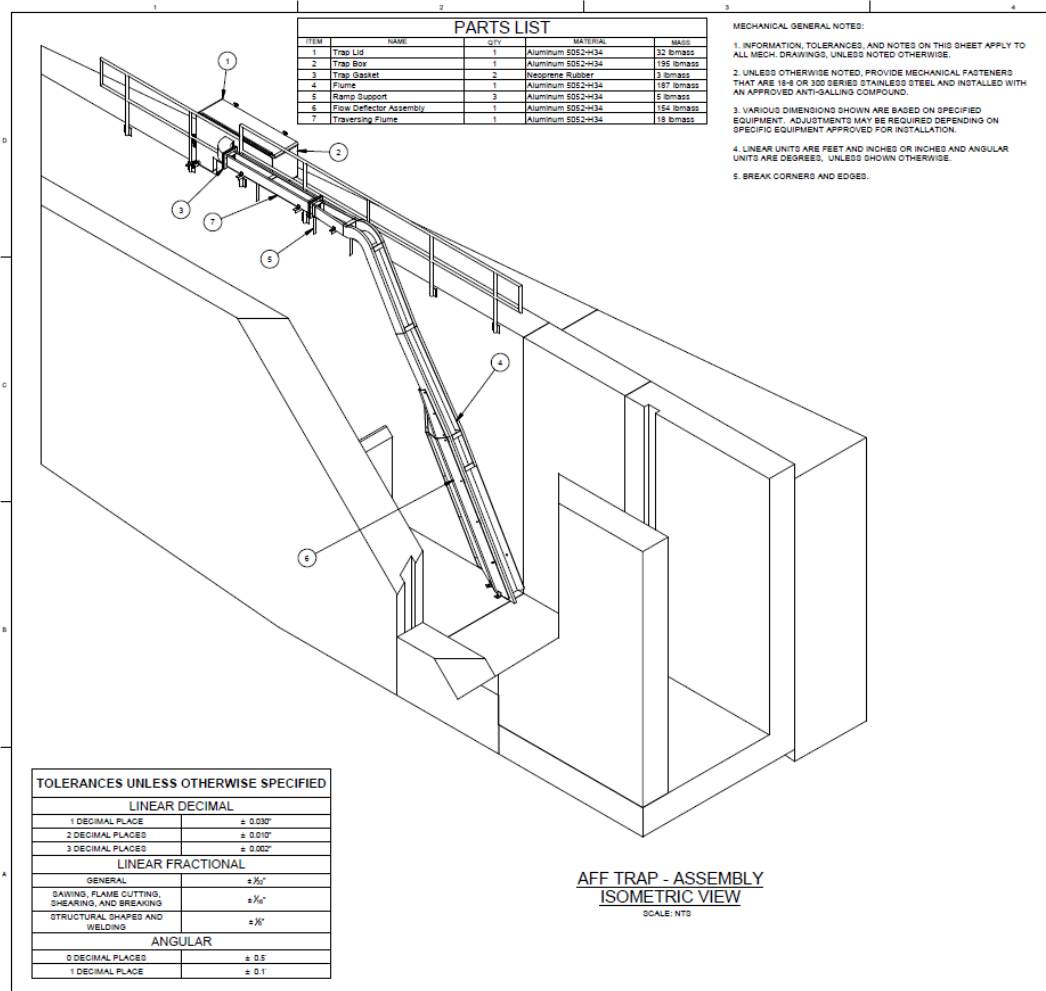

**Figure 2.** Isometric drawing of the adult lamprey trap in the Adult Fish Facility ladder to be installed by mid-April.

### Washington Shore LPS plunge box

The problem was first identified in 17BON16 MFR – Modifications to WA Shore AWS LPS Exit Chute (09June2017).

On 08 June 2017, FFU biologists informed Project Fisheries of recent video validation results from the new counter at the WA Shore AWS LPS exit chute. Upon reviewing of 6 hours of video, there were 47 passage events. Seventeen

of them (36%) appear to have either splashed, grazed, or slightly impacted the concrete section of the bridge over the fishway; creating the possibility of removing some slime coat or worse.

On the morning of 09 June, Project Fisheries, FFU, and Portland District biologists observed fish making the same contact with not only the concrete on the bridge as observed in video but also along the opposite fishway wall nearest the water level of the ladder.

A plan was devised to minimize contact as observed in the video and prevent lamprey from making contact on the opposite wall altogether. Materials used on STSs (submergible traveling screens) were shaped to form a cone of sorts, gently guiding fish away from both walls. A more permanent solution will be investigated and installed.

This MOC, in part, is a request to install the permanent fix later this month or the first week in April (19 March to 15 April 2018). The installation date is dependent on fabrication of the box. The plunge box will be installed on the fishway wall (figure 3). This will require hand tools and someone in a man basket above the water line within the fish ladder. The work will occur while the fish ladder is in FPP criteria and will take up to 4 hours one day to complete by Bonneville project staff.

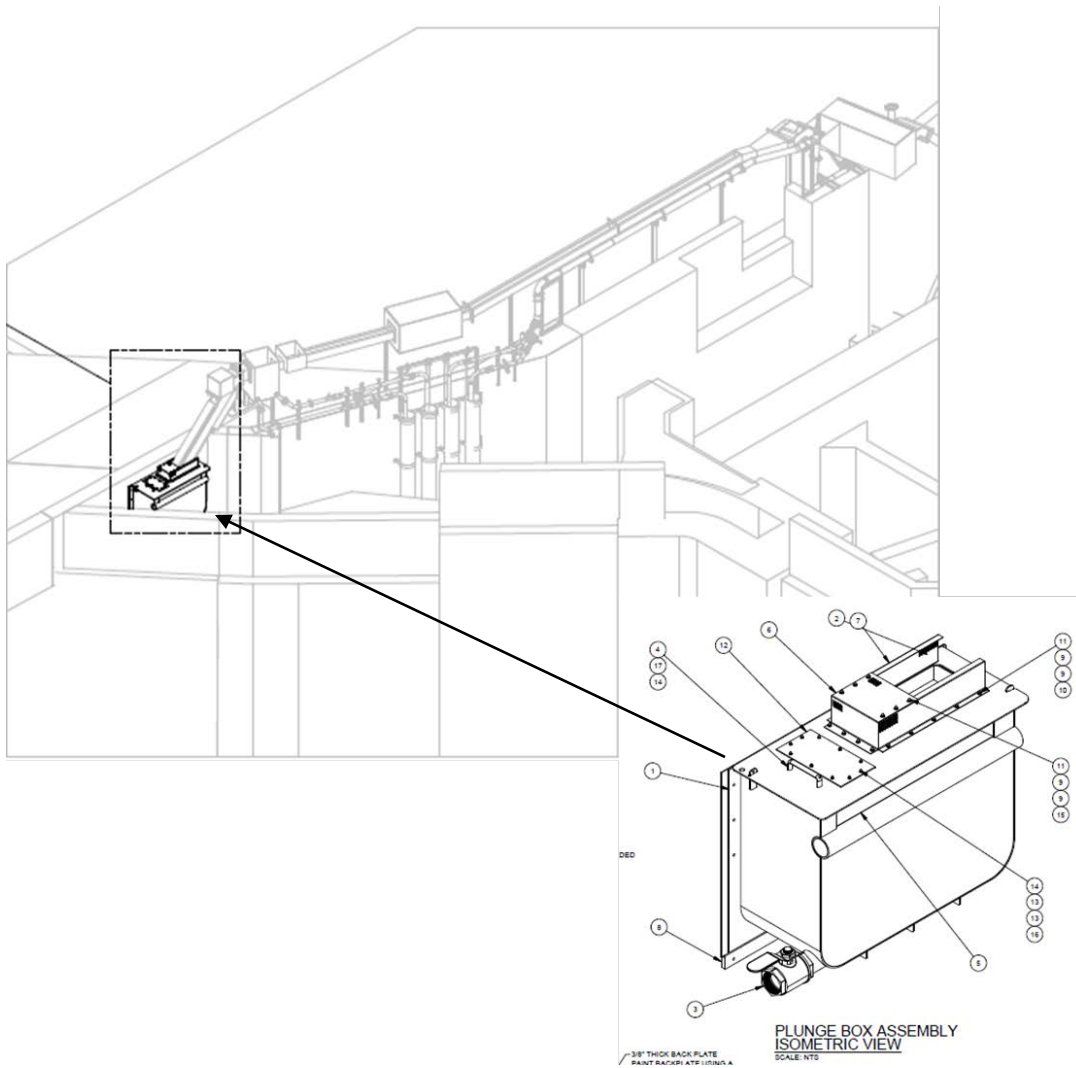

**Figure 3.** The Washington shore LPS is shown with an enlarged isometric of the plunge box to be installed near the fish ladder exit.

**Impact on facility operation**

Work within 50 feet of the Washington shore fish ladder (FPP section 2.1.5) to install a plunge box and adult lamprey trap in the AFF fish ladder (figure 1).

**Dates of impacts:** One 4 hour window from 19 March to 15 April 2018 (plunge box installation). April 18<sup>th</sup> and 19<sup>th</sup> (AFF lamprey trap installation).

## Analysis of potential impacts to fish

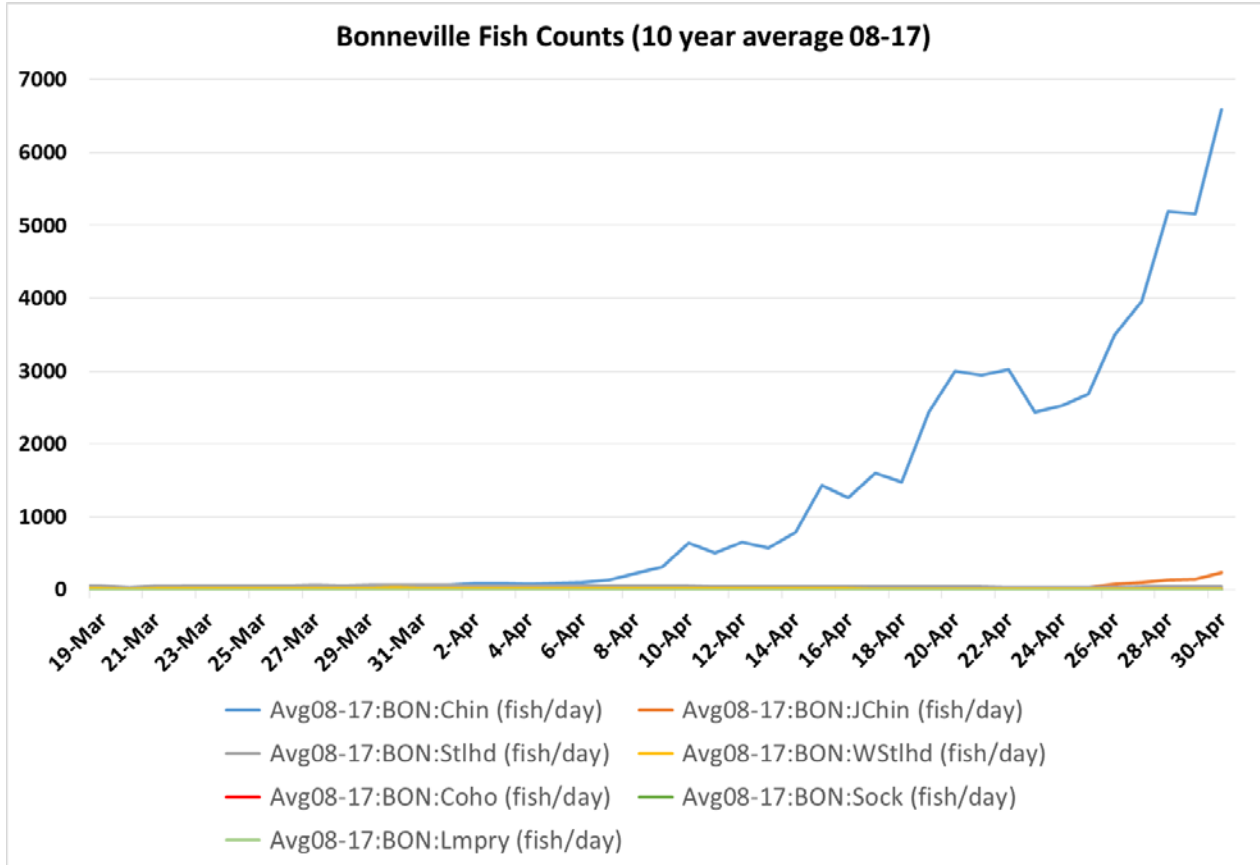

**Figure 1.** 10 year average (2008 to 2017) Bonneville Dam counts from Columbia River DART at [www.cbr.washington.edu/dart/query/adult\\_graph\\_text](http://www.cbr.washington.edu/dart/query/adult_graph_text).

### Downstream migrants

There are no expected impacts to steelhead kelts, juvenile salmonids, or juvenile lamprey as a result of the proposed work.

### Upstream migrants (including Bull Trout)

Based on the 10 year average adult fish passage at Bonneville Dam there should be very little impact if any to salmonids or lamprey prior to April 5<sup>th</sup>. This timeframe includes the proposed timing of the installation of the lamprey plunge box. It requires work, using hand tools, above the water line in the fish ladder at the Washington Shore fish ladder exit for a total of 4 daylight hours.

The installation of the lamprey trap in the AFF fish ladder will occur when Chinook Salmon are present in significant numbers at the WA shore fish ladder. However there should be minimal impact to passage since the work will occur within the AFF fish ladder and only hand tools will be used to anchor the flume. The installation date is April 18<sup>th</sup> and 19<sup>th</sup> when numbers are between 2000 and 3000 fish at Bonneville Dam.

There are no anticipated impacts to bull trout as a result of the work near the fish ladders.

**Lamprey**

There will be no impact to adult lamprey passage during the installation of the lamprey trap in the AFF fish ladder. There will be little or no impact to lamprey passage during the installation of the plunge box. The first adult lamprey generally do not arrive until May.

**Final coordination results** – From the March meeting minutes: FPOM concurred with the installation of the plunge box and with the installation of the AFF trap as long as it is completed by 15 April.

**After Action update**

The plunge box was installed April 5<sup>th</sup> and the AFF lamprey trap was installed April 21<sup>st</sup>, 2018.

Please email or call myself or Erin with questions or concerns.  
Thank you,

Ricardo Walker

[Ricardo.walker@usace.army.mil](mailto:Ricardo.walker@usace.army.mil); (503) 808-4709

Erin Kovalchuk

NWP Operations Division Fishery Section

Columbia River Coordination Biologist

[Erin.H.Kovalchuk@usace.army.mil](mailto:Erin.H.Kovalchuk@usace.army.mil)